

BIRD SCREEN DETAIL

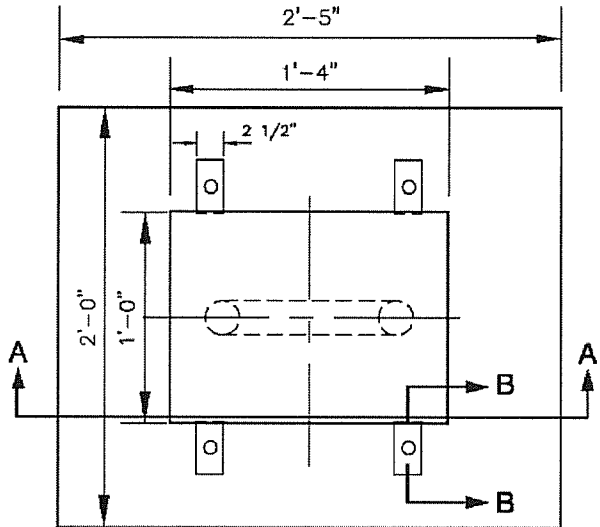

PLAN

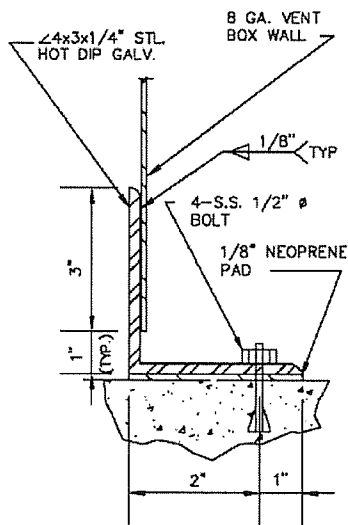

SECTION B-B

1. ALL METAL FABRICATION SHALL BE DONE IN ACCORDANCE WITH SPECIFICATION.
2. ALL WELDED JOINTS SHALL BE CONTINUOUS COMPLETE PENETRATION WELDS UNLESS OTHERWISE NOTED.
3. THE BOX ASSEMBLY SHALL BE HOT DIP GALVANIZED AFTER FABRICATION.

IN FLOOD PLAINS, THE VENT PIPE OUTLET SHALL BE 1'-0" MINIMUM ABOVE THE 100-YEAR FLOOD ELEVATION. SEE DRAWINGS FOR ELEVATION.

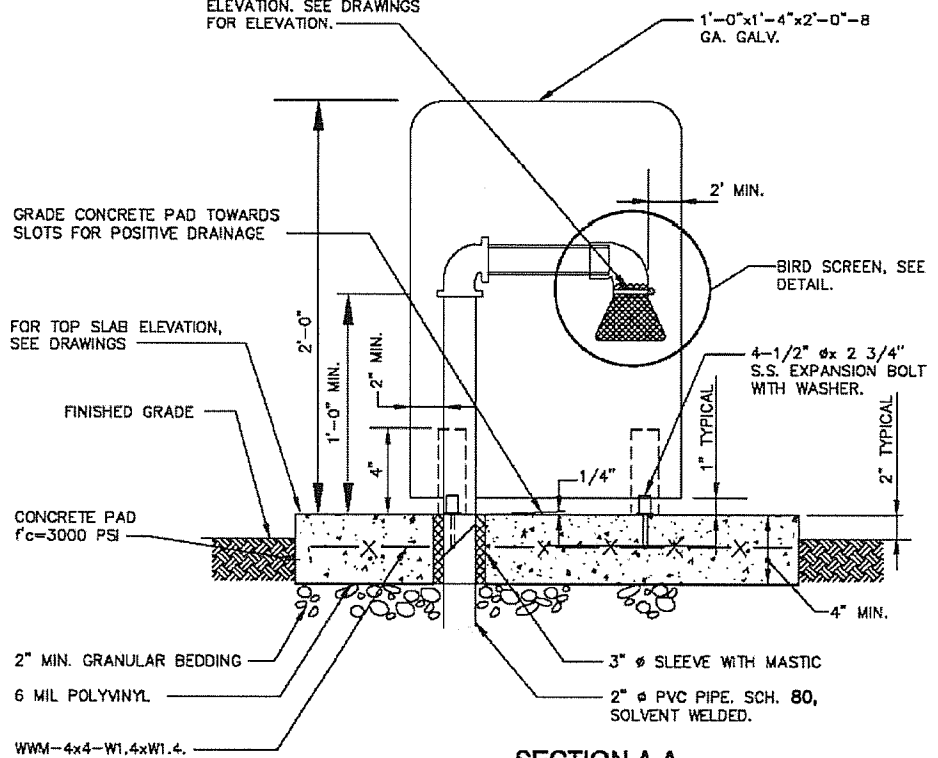

SECTION A-A

STANDARD DETAIL
VENT BOX FOR
EXTENDED AIR
RELEASE PIPE

WASHINGTON TOWNSHIP MUNICIPAL AUTHORITY

DATE	REVISIONS
SCALE NO SCALE	DWG. NO. ARV-3