

**GENERAL NOTES:**

1. ALL CONCRETE SHALL BE HIGH EARLY STRENGTH WITH  $f'_c = 4000$  PSI @28 DAYS.
2. PRIOR TO PLACING BITUMINOUS PAVEMENT, ALL UTILITY STRUCTURES SHALL BE BROUGHT TO GRADE. BACKFILL AROUND UTILITY STRUCTURES WITH STRUCTURAL FILL.
3. REMOVE EXISTING CONCRETE DRIVEWAY TO NEAREST JOINT WHEN SO DIRECTED BY THE ENGINEER.
4. ALL EXPOSED EDGES OF EXISTING BITUMINOUS PAVEMENT AND SURFACE OF GRAVEL BASE SHALL BE PRIMED BEFORE THE BITUMINOUS MIXTURE IS PLACED.

**CONCRETE DRIVEWAY**

CLEAN AND WET EDGES OF CUTS BEFORE PLACING CONCRETE.

COMPACT AND DAMPEN SUBGRADE BEFORE PLACING REBARS.

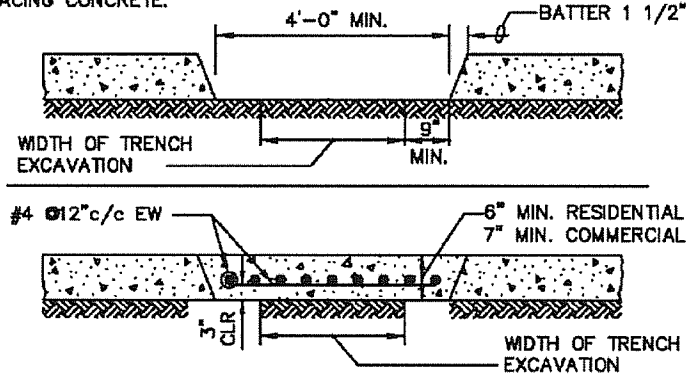

**BITUMINOUS DRIVEWAY FULL DEPTH**

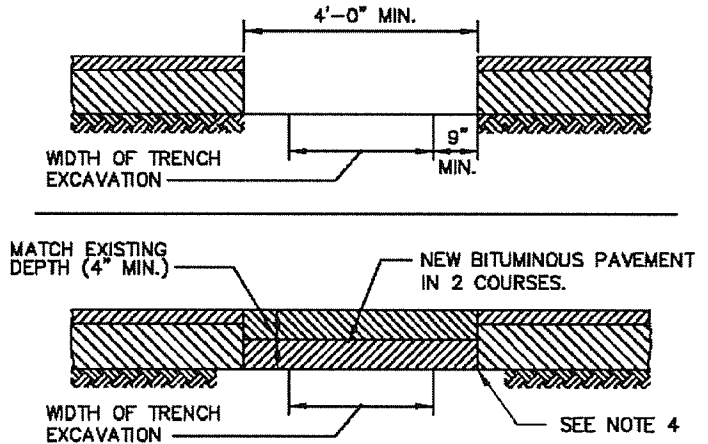

**BITUMINOUS DRIVEWAY OVER GRAVEL**

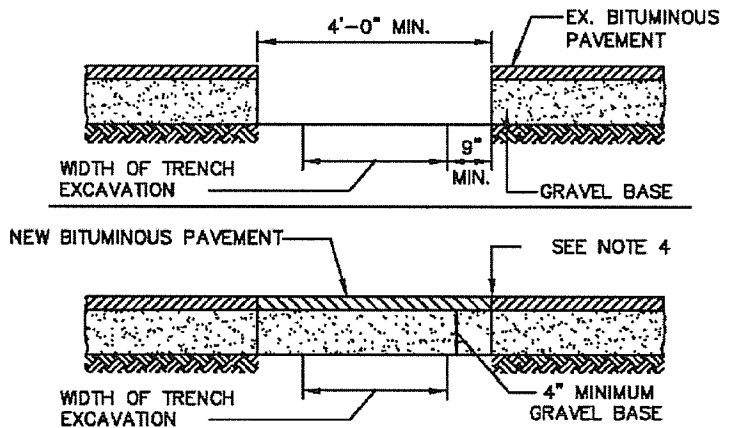

STANDARD DETAIL  
METHOD OF CUTTING  
AND REPAIRING  
DRIVEWAYS

WASHINGTON TOWNSHIP MUNICIPAL AUTHORITY

DATE	REVISIONS
SCALE NO SCALE	DWG. NO. W-7